

Site Specific Notes:

- The owner/Developer of the property is NN Out Properties LTD. The subject property is City of Bryan Townsite Block 96, Lot 2R & 3R, 0.989 Ac.
- The proposed building is a Type VB, three stories, with sprinklers, 6,734 sf, FF = 368.00', Height = 35'.
- This property is Zoned (MT-C) Midtown Corridor.
- Fire flow demand is 1,500 gpm. The existing hydrant at W 33rd St. will provide the hydrant flow for this project.
- This lot is not within the 100-yr floodplain according to the Dfirm for Brazos County, Texas and Incorporated Areas, Map No. 48041C0215F, effective April 02, 2014.
- The developed area for this project is 0.39 acres (16,988 sf), with 79% Impervious Cover for Lot 3R & 68% Impervious Cover for Lot 2R
- Solid waste pickup will be one side load dumpster.
- Proposed Signage must be permitted separately.
- All On-Site, Private Drive Aisles & Parking are covered by a Shared Parking, Access & Drainage Easement granted by plat. (____/____).

Construction Notes:

- 6x10 dumpster pad w/ 8" thick reinforced concrete #5 rebar @ 12" O.C.E.W. Prior to placement of concrete contractor shall contact Kyle McCain with solid waste @ 979-209-5900 for inspection.
- All concrete to be constructed with 3,500 psi (Min) - 28 day strength portland cement concrete.
- All items to be removed during clearing and grubbing. Remove not only the above ground elements, but all underground elements as well. All excavated material shall become the property of the contractor unless otherwise directed by the Owner. All debris must be disposed of off site.
- Prior to grading operations, contractor is to strip the first 6" of soil. Contractor shall proof roll the entire site and remove any unstable materials according to TxDOT Specifications. Select fill is to be used in replacing objectionable material.
- Assure positive drainage across project site to the storm water structures.
- Normal Domestic Wastewater is anticipated to be discharged from this development.
- Potable Water Protection - All devices, appurtenances, appliances, and apparatus intended to serve some special function and that connects to the water supply system, shall be provided with protection against backflow and contamination of the water supply system. As noted in Texas Administrative code 30 TAC 290.47 - Appendix F.
- Irrigation System - Potable water supply must be protected by either an atmospheric or pressure vacuum breaker, or testable double check valve assembly, and installed per City Ordinance.
- Each utility contractor is responsible for positioning and trenching of service lines. Mark all lines with utility tape. Utility contractors are responsible for coordinating with paving contractor in placement and installation of any necessary utility conduit prior to subgrade preparation. Lines requiring slope control are to be installed first. All other lines not requiring slope control or elevation shall be installed deepest first. Each contractor is responsible for knowing final determination of installation order.
- Materials and methods for pavement markings shall conform to TxDOT Standard Specifications for Construction of Highways, Streets, and Bridges (current edition), with the following exceptions: 1) Type II marking materials need not be purchased from the Department, and 2) Glass beads may be omitted, but marking material shall be Type II paint-type material.
- The Contractor shall be responsible for the containment and proper disposal of all liquid and solid waste associated with this project. The Contractor shall use all means necessary to prevent the occurrence of windblown litter from the project site.
- Demolition/Construction Waste - Site is required to provide containment for waste prior to and during demolition/construction. Solid waste roll off boxes and/or metal dumpsters shall be supplied by City to permitted contractor(s) only.
- Contractor is responsible for field verifying existing and proposed grades prior to any construction and reporting any inconsistencies to the Owner.

Parking Analysis:

Proposed Improvements:
18 1 Bedroom Studio Apartments

New Required Parking:
18... 1 Space per Bedroom

18... Total Required

Total Proposed Parking
16... Straight in Parking
6... Parallel Parking
2... ADA Parking
24... Total Provided

Utility Notes:

- Private water line and private sanitary sewer line construction shall be in accordance with the plumbing code. Cleanouts shall be installed per plumbing code.
- Private water and sewer line service materials to be in accordance with plumbing code.
- Contractor shall coordinate conduit and/or line installation for telecommunication providers for the site.
- Depth of the existing water and sewer lines to be verified by the contractor.
- Traffic control for utility work shall be provided by the contractor as needed.
- Where electric facilities are installed, BTU has the right to install, operate, relocate, construct, reconstruct, add to, maintain, inspect, patrol, enlarge, repair, remove, and replace said facilities upon, over, under, and across the property included in the PUE, and the right of ingress and egress on the property adjacent to the PUE to access electric facilities.

Fire Lane Striping:

From the point the fire lane begins to the point the fire lane ends, including all curbs, curb ends and behind all parking spaces which adjoin a fire lane, shall be marked with one continuous 8" red stripe painted on the drive surface behind the parking spaces, and all curbs and curb ends shall be painted RED with 4" white lettering stating "FIRE LANE-NO PARKING-TOW AWAY ZONE." Wording may not be spaced more than 15 feet apart.

■ FIRE LANE ■ NO PARKING ■ TOW AWAY ZONE ■

Note: Fire Lane linework shown on this Site Plan is used to delineate the location of the fire lane for permitting purposes.

NOTICE!

The contractor is specifically cautioned that the location and/or elevation of the existing utilities as shown on these plans is based on records of the various utility companies and, where possible, measurements taken in the field. The information is not to be relied upon as being exact or complete. It is the contractor's responsibility to avoid all existing utilities and repair any damaged lines, at his own expense, whether the utility is shown on these plans or not. The contractor shall notify the appropriate utility company 48 hours prior to any excavation.

Contact Information:

Texas One Call: 800-245-4545
Lone Star One Call: 800-669-8344
Texas Excavation Safety: 800-344-8377
City of Bryan: 979-209-5900
System (Digtest):
Bryan Texas Utilities: 979-821-5885
Atmos Energy: 979-774-2506
Frontier: 979-821-4300
Suddenlink: 979-846-2229

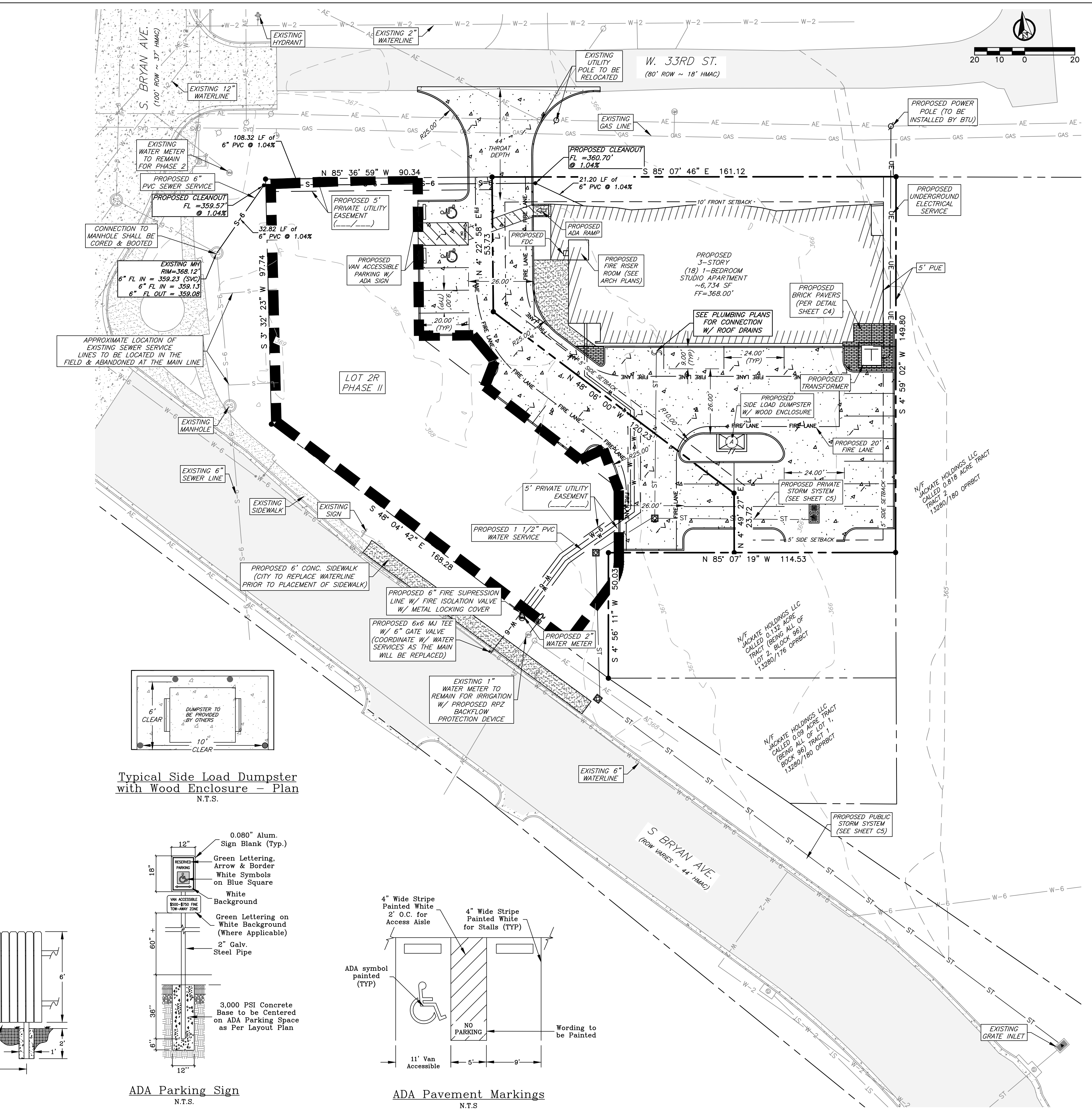
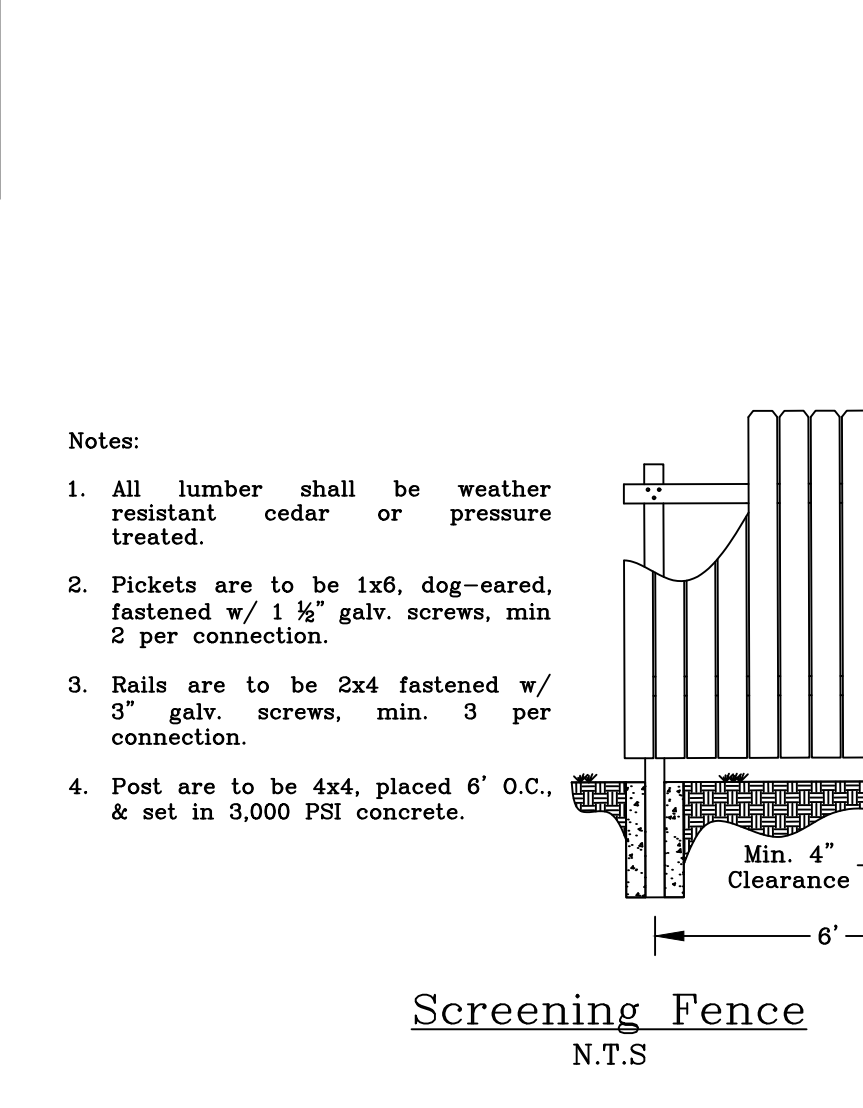

Site Plan

General Notes:

- The topography shown is from field survey data.
- Refer to Final Plat for all lot dimensions and bearings.
- A property owner's association (POA) shall be established with direct responsibility to, and controlled by the property owner's involved to provide for operation, repair and maintenance of all common areas, private drainage easements, and private stormwater detention facilities which are part of this subdivision. The city of Bryan shall not be responsible for any operation, repair and maintenance of these areas.
- All utilities shown are taken from the best available information based on construction utility documents obtained by J4 Engineering from City and independent agencies and/or above ground field evidence. Shown positions may not represent as-built conditions.
- The contractor shall be responsible for verifying the exact location of all existing underground utilities, whether shown on these plans or not. Notification of the utility companies 48 hours in advance of construction is required.
- All construction shall be in accordance with the current BCS Standard Specifications, Details, and Design Guidelines for Water, Sewers, Streets, and Drainage, unless otherwise noted.
- It is the intent of these plans to comply with all City of Bryan guidelines, details, and specifications.
- See Sheet C1 - General Notes.

**Preliminary Plans Only
Not for Construction**

This document is released for the purpose of interim review under the authority of Glenm Jones, P.E. 97600 on 12-Jul-22. It is not to be used for construction, bidding, or permitting purposes.

Released for Review

| No. | Revision/Issue | Date |
|-----|----------------|------|
| | | |
| | | |
| | | |

Firm Name and Address:

J4 Engineering
PO Box 5192 - Bryan, Texas - 77805
979-739-0567 www.J4Engineering.com
Firm# 9951

Project Name and Address:

Marco Polo Ph. I
801 S. Bryan Ave
City of Bryan Townsite
Block 96, Lots 2R & 3R -0.989 Ac
Bryan, Brazos County, Texas

| | |
|------------------------|---------------|
| Date: July 2022 | Sheet: |
| Scale: As Noted | C2 |

J4 Engineering 07/12/2022 Marco Polo Ph. I - Site Plan 3.dwg J4 Project # 21-042